

Lab 2: Reactive agents: Alice, Braitenberg, and Brooks

Submit:

- Your group responses (within a zip file) to <http://www.deei.fct.ualg.pt/IA/Entregas/>

Up to January 9, 2009, 9H00 AM

1.



Chat for a while with ALICE (<http://alice.pandorabots.com/>) as if you were talking with a stranger for the first time. The subject of your talk is totally free and completely up to you.

- a) Record your dialog, and the duration of the conversation;
- b) How intelligent does your interlocutor seem to you? Please justify your answer.
- c) Speculate on the architecture of this chatterbot.

2. Braitenberg described a set of vehicle that can exhibit complex behaviour despite its simplicity. Describe the behaviour of the vehicle below, knowing that the arcs at the

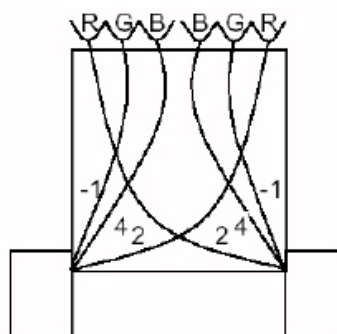

the front represent sensors sensible to R-Red, G-Green, and B-Blue light, respectively. The sensors are connected to the drive wheels by weights that can be excitatory (+) or inhibitory (-).

3. A robot operating in the rocky mountains aims at reaching their highest point, without colliding with any major rock. The robot is equipped with two inclinometer sensors that indicate the terrain surface gradient. One of the inclinometers gives the gradient in the direction that the robot is heading (hereafter referred to as current direction), while the other gives the gradient in the direction normal to the robot

current direction. The robot has also an ultrasonic sensor that indicates the distance to obstacles in front of the vehicle.

- a) Design a Braitenberg vehicle able to accomplish this mission
- b) Design a Brooks's subsumption architecture for this robot.

Submit:

- Your group responses (within a zip file) to <http://www.deei.fct.ualg.pt/IA/Entregas/>

Up to January 9, 2009, 9H00 AM